

Creativity and dyslexia

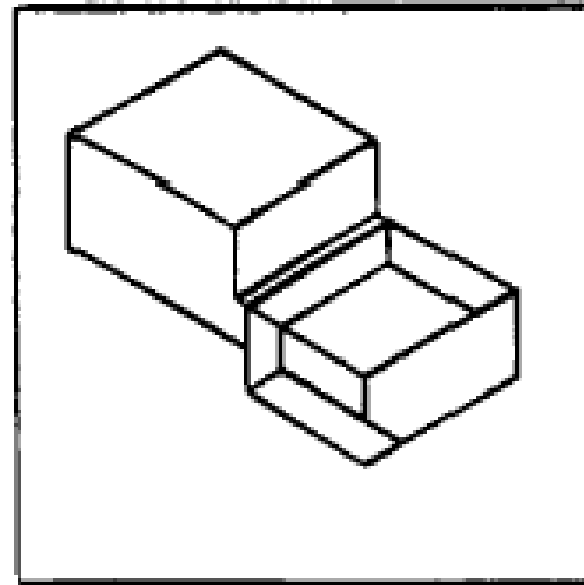

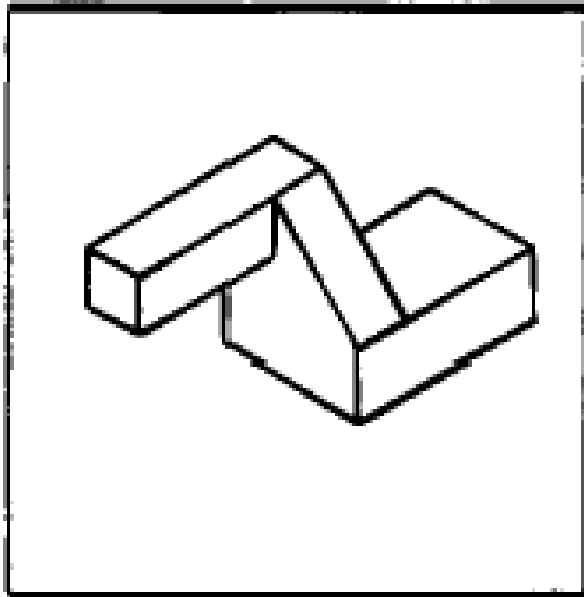

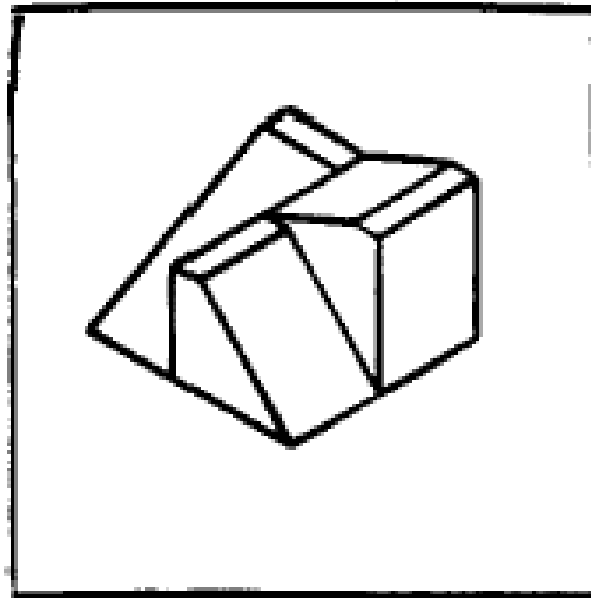

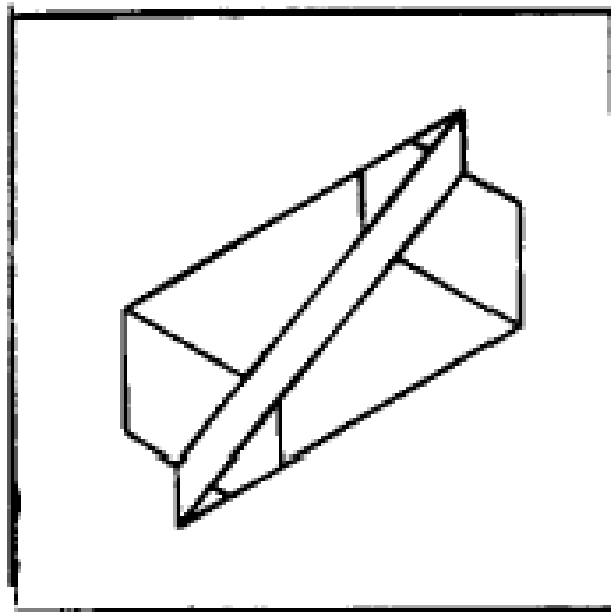
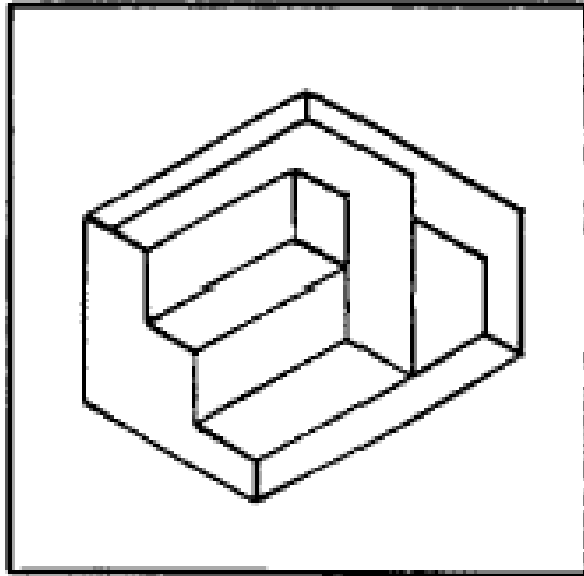

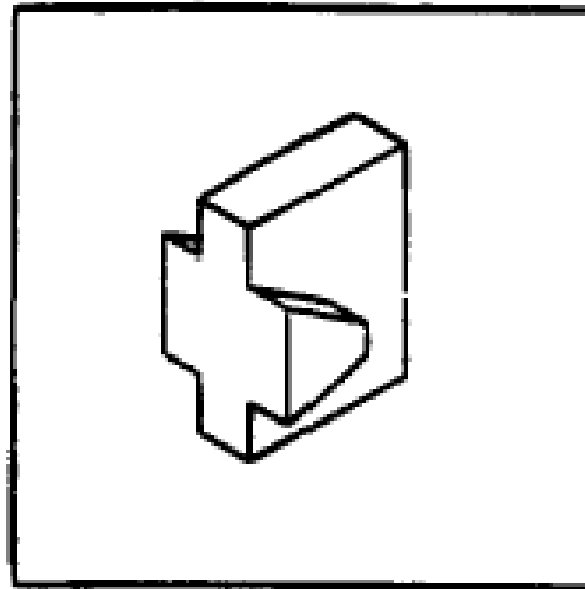

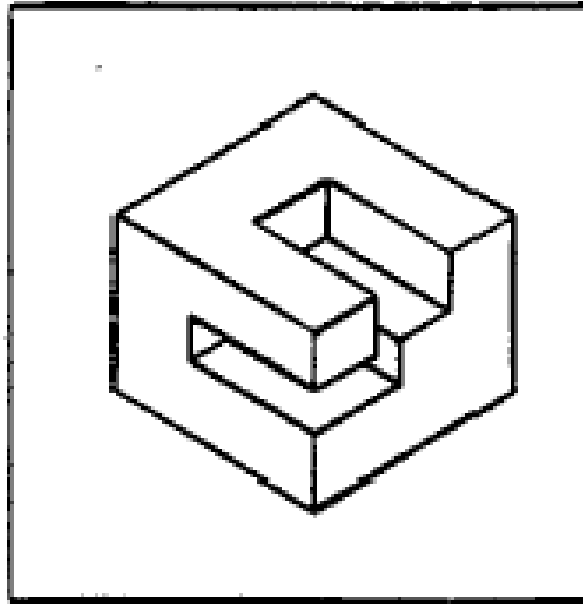

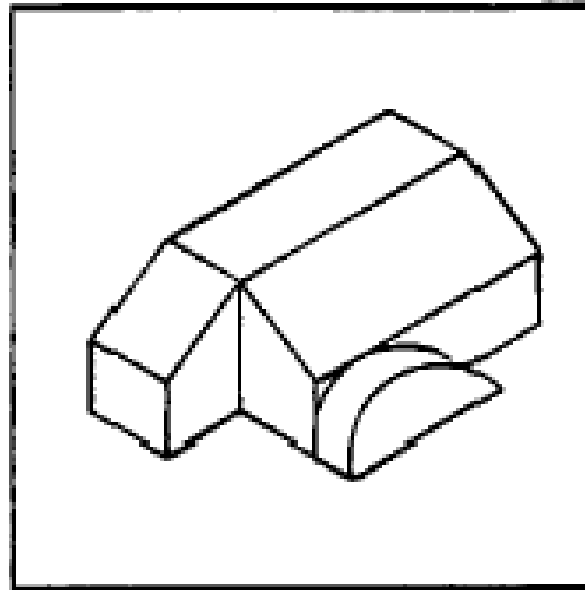

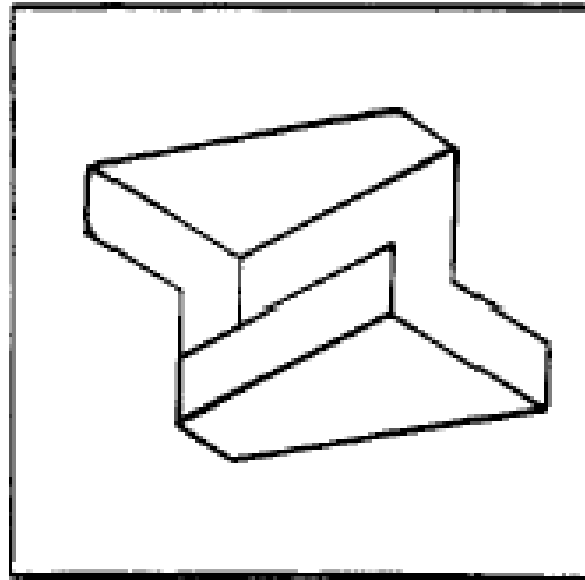

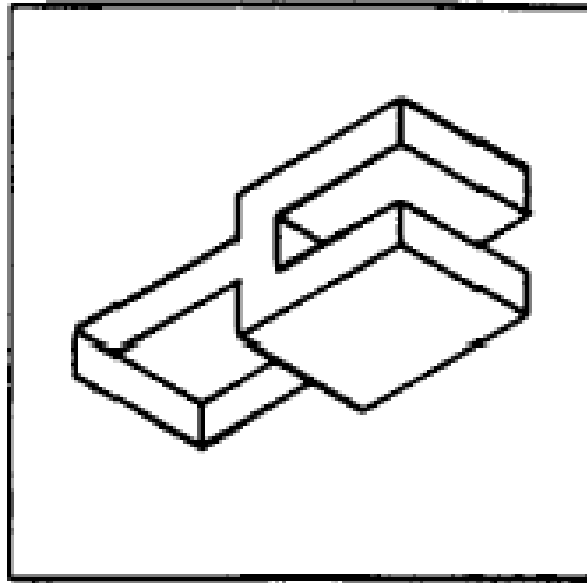

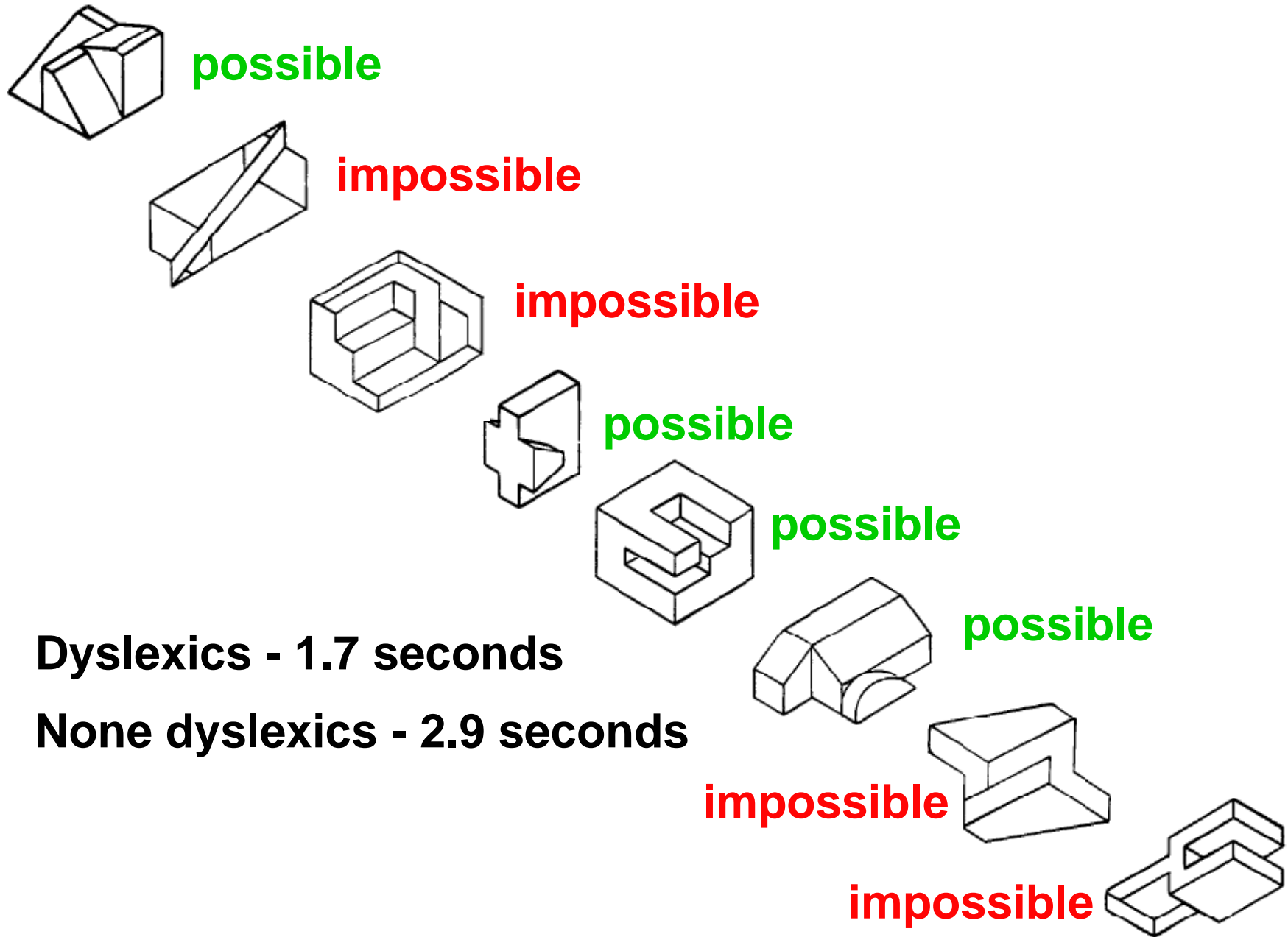

Dyslexics - 1.7 seconds

None dyslexics - 2.9 seconds

Creativity and dyslexia

- **disproportionate number of artists, architects, engineers and entrepreneurs are dyslexic (so are those in prison)**
- **most reading problems - fundamental sensorimotor cause**
- **clear genetic evidence**
 - **“abnormal” brain development in utero**
- **10% of the population exhibit these problems**
- **compensating advantage - stronger connectivity**
- **visuo-spatial, holistic, artistic, “seeing the whole picture”**
 - **entrepreneurial talents & unusual creativity**